



GK3 P SP

Is our most advanced unit for combined production of shakes and sundaes. Flavour the Evolution



A shake & sundae heat-treatment combo freezer. This model allows you to pasteurize on one side, while keeping the other side running

Two independent freezers

It features two independent, high-volume freezers in one compact structure. If needed, one side can be stopped, while the other side remains in full operation

Super flexibility

this model reaches max 42 days cleaning interval



*request them from your dealer to always keep your machine hygienically perfect.

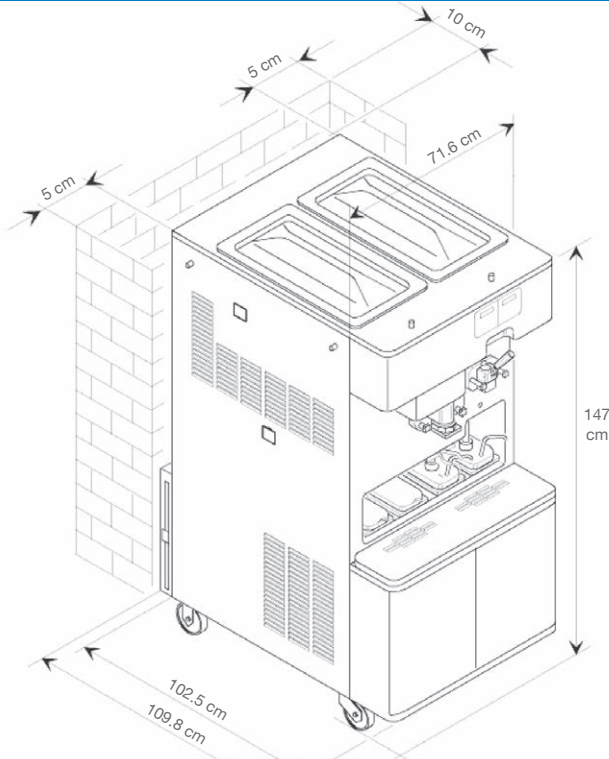

Optional configurations



Teorema Remote Control

It gives very important info about the machine, it facilitates the service system and helps the cleaning schedule



Mixer

Optional mixer with disposable spoons to swirl toppings into the ice cream



Dry Filling System

Possibility of preparing the mix directly in the hopper by adding water and dry mix



Cone and cup dispenser

Easy to mount on both sides. Cones and cups always "handy"

	Flavours	Mix Delivery System	Hourly production*	Tank Capacity	Cylinder Capacity	Rated Power Input	Fuse Size	Power Supply**	Cooling System	Refrigerant***	Net Weight
				lt	lt	kW	A				kg
GK3 P SP	Soft 1 Shake 1+4 syrups	Pump	(75gr portions) Soft 500 (16oz / 0,4lt) Shake 170	20 + 20	Soft 1.75 Shake 7	4.8	16	400/50/3	Air Optional Water	R452	395

* production capacity depends on the mix used and the room temperature ** other voltages and cycles available upon request *** alternative solutions available

Features

Benefits

Two independent refrigeration system in one frame	Allow to work with one side, while the other side can pasteurize or can be stopped
Stainless steel pressurized pump with gears in Advanced Thermoplastic Polymer	The pump ensures the best ice cream texture, quality and high overrun, adjustable from 40% to 80%
Peristaltic pump syrup delivery system with external syrup valves	Ensure good functionality with fluids or thick syrups that contain solid fruit particles
Interactive display	Communicates with the operator delivering instructions and data regarding machine performance
Tank agitators	Prevent product stratification and helps to reduce foam by maintaining a fluid consistency
Adjustable product flow	Adjustable product flow to meet your specific dispensing speed and volume requirements
1 neutral + 4 different shake flavours are dispensed automatically	Press the button to start dispensing the flavoured shake. It will automatically stop based on container size.
Fountain pump and covered containers for toppings	Two fountain pumps for hot topping and two covered containers for cold toppings
Direct expansion cooling cylinders	Optimize refrigeration efficiency for fast freeze downtime, less waste of product ensuring higher quality and energy saving
Defrost system	Possibility to heat the cylinders to simplify the cleaning procedure

GK3 P SP is produced by Carpigiani with Quality System UNI EN ISO 9001.
All specifications mentioned must be considered approximate;
Carpigiani reserves the right to modify, without notice, all parts deemed necessary.